

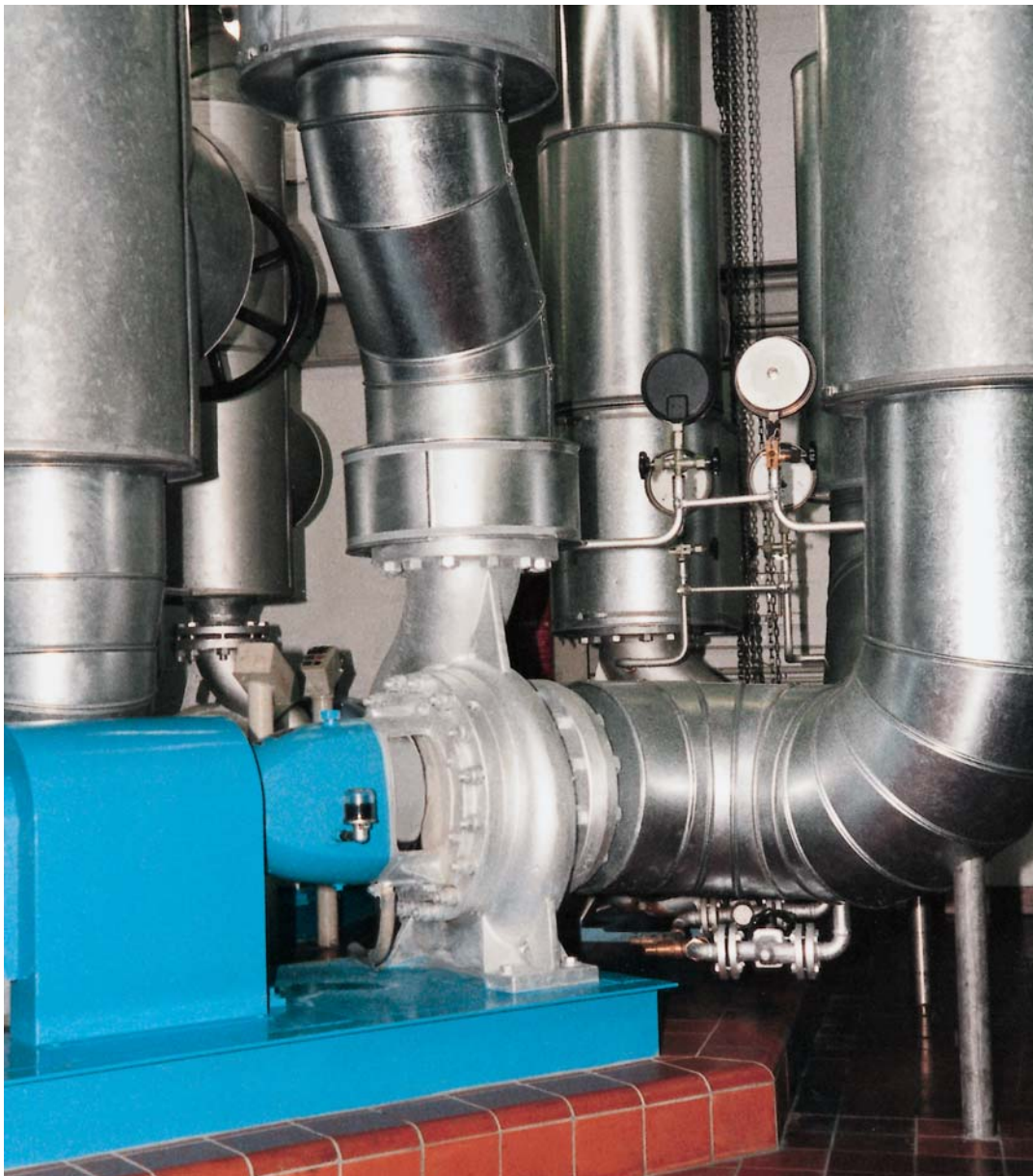

**DICKOW
PUMPEN**

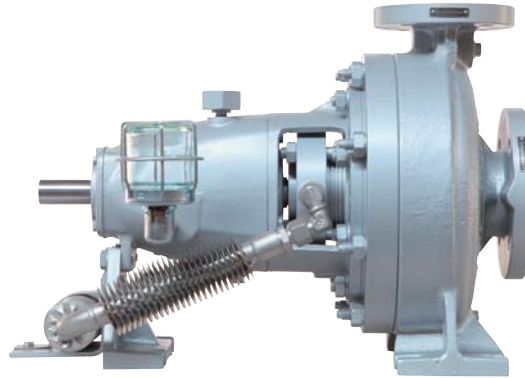

**Hot Water Circulation Pumps
Type NHL / HPL / HPR / NHM**

GENERAL

DICKOW hot water circulation pumps, type NHL, HPL, HPR and NHM, have been developed for medium and large size heating plants, for heating calanders, presses, large buildings and similar applications which require temperatures $>140^{\circ}\text{C}$ (284°F).

The design of the pumps is based on long years of experience in the field of handling hot water and grants high availability and reliability in operation.

The NHL series is designed for pressures up to 45 bar @ 238°C (464°F), maximum capacity is appr. $900\text{ m}^3/\text{h}$ (3960 gpm) and differential head appr. 150 mLC (492 ft).

The HPL / HPR series is designed for pressures up to 80 bar @ 280°C (536°F), maximum capacity is appr. $300\text{ m}^3/\text{h}$ (1320 gpm) and differential head appr. 60 mLC (197 ft).

DESIGN

The pumps are single stage volute casing pumps in "back-pull-out" design with end suction and top centerline discharge flange. The "back-pull-out" design allows disassembly of the rotating pump parts without removing the volute casing from the piping system.

For fully utilizing the advantage of the "back-pull-out" design, use of spacer-type couplings is highly recommended because the driver can then remain bolted to the base plate.

Volute Casing

Casings with rigid foot mounting are supplied as a standard for the NHL / NHM type.

The casing bolts are of heat resistant expansion type. For applications with temperature swing, additional cup springs avoid leakage, caused by thermal expansion.

Confined gaskets avoid blow-out of the liquid.

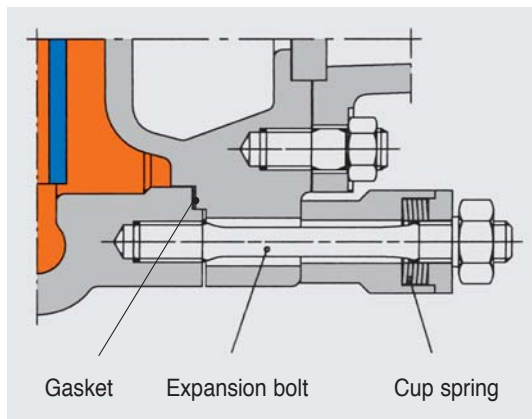

Centerline mounted design according to API 610 / ISO 5199 is available for high operating temperatures on request.

This minimizes thermal stress and misalignment of the coupling due to heat expansion of the casing during operation.

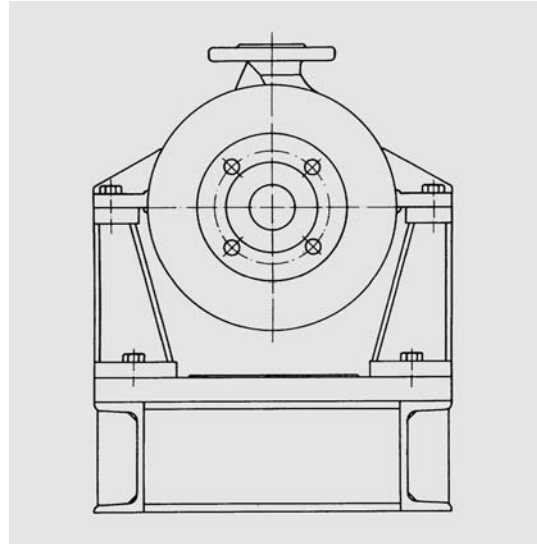

All of the HPL / HPR-pumps will generally be provided with centerline mounted casings.

Impellers

Impellers are casted in one piece with solid hubs. To minimize thrust loads, the closed impellers are hydraulically balanced by wear rings and balance holes in the impeller hub. The impellers are keyed to the pump shaft and secured by cap screws with Heli-Coil-inserts. The impellers are properly statically and dynamically balanced according to DIN ISO 1940T1 Grade 6,3.

Wear rings

Volute casing and intermediate casing are both fitted with renewable wear rings held in place by a press fit with locking screws.

Additional impeller wear rings available as an option. The running clearances are in accordance with API 610.

Shaft, shaft sleeve

The pump shaft is able to transmit the full driver output and is accurately machined throughout its entire length and is properly finished at the bearing surfaces.

In order to have satisfactory seal performance the shaft diameter and overhung are sized to minimize shaft deflection at the seal faces.

The shaft design guarantees a critical speed of more than 10 % over the maximum operating speed. The connections "cap screw – hub" and "hub – shaft sleeve" are sealed by confined gaskets and the pump shaft has no contact to the pump fluid.

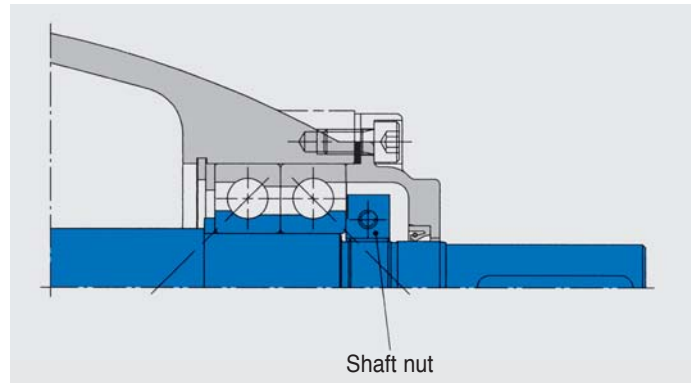

The roller bearings take the remaining hydraulic radial loads. The bearings proved a life time of more than 25000 operating hours even under severe conditions.

If required, bearing bracket cooling is available, on request.

Antifriction bearings

The pump shaft is carried by generously dimensioned antifriction bearings outside the pumped liquid. The bearings are oil-lubricated. The oil level in the bearing bracket is regulated by a constant level oiler.

The standard design has angular ball bearings on the coupling side fixed on the pump shaft in axial direction by circlips. The HPL-pumps and NHL-pumps in temperature swing applications are provided with shaft nuts.

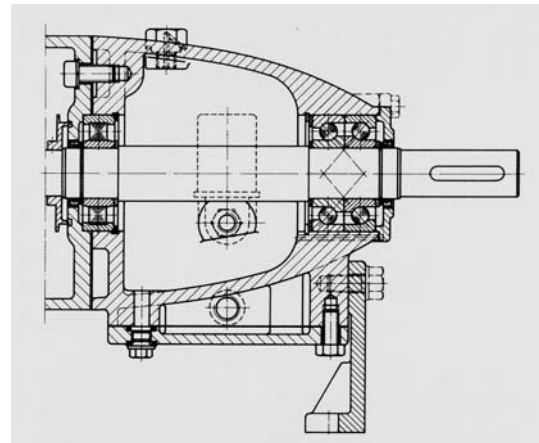

APPLICATION LIMITS

NHL s:	NHL huh:	HPL / HPR huh:
Temperatures up to 205° C (401°F).	Temperatures up to 238°C (464°F).	Temperatures up to 280°C (536 °F).
Operating pressures up to 22 bar (320 psi).	Operating pressures up to 45 bar (650 psi).	Operating pressures up to 80 bar (1160 psi).

STANDARD MATERIALS

Part	Pump type		
	NHLs	NHLhuh	HPLhuh
Volute casing	GGG40.3	1.7706	1.7706
Impeller	GG25	GG25	GG25
Intermediate casing	GGG40.3	1.7706	1.7706
Pump shaft	1.4021	1.4021	1.4021
Shaft sleeve (mech. seal)	1.4571	1.4571	1.4571
Seal faces (mech. seal)	Carbon/SiC	Carbon/SiC	Carbon/SiC
Bearing bracket	GG25	GG25	GG25
Bearing bracket lantern	GG25	GG25	GG25
Shaft sleeve (packing)	1.4571/coated	1.4571/coated	1.4571/coated
Casing screws	1.7258	1.7258	1.7258

NHL-Design

volute casing
centerline mounted

heavy duty
antifriction
bearings

bearing bracket
oil lubricated

replaceable
wear ring

deflector

drain plug

closed impeller

confined gasket

seal chamber

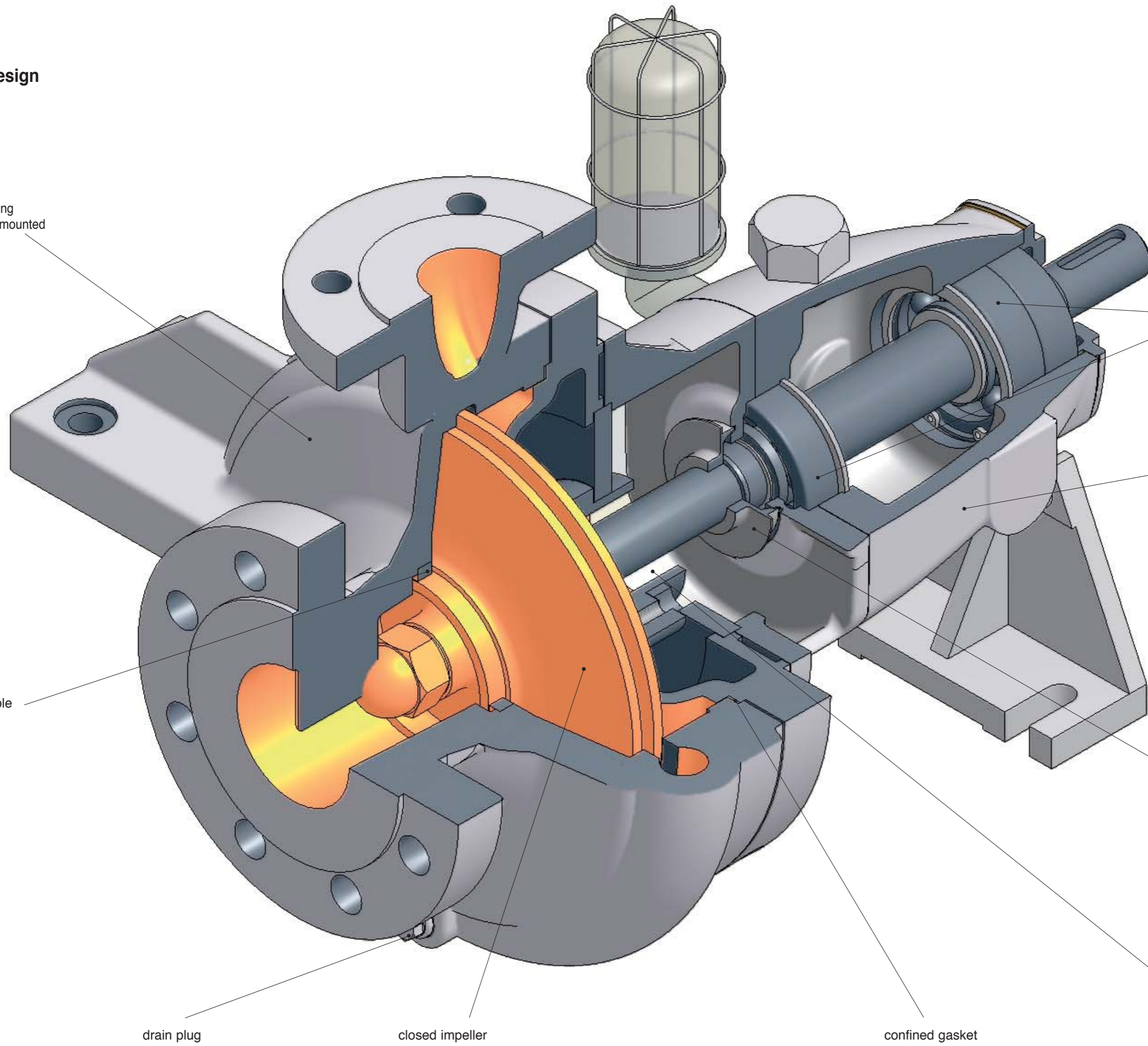

SHAFT SEALING

Due to high vapour pressures of hot water, standard mechanical seals can not be used for high temperatures.

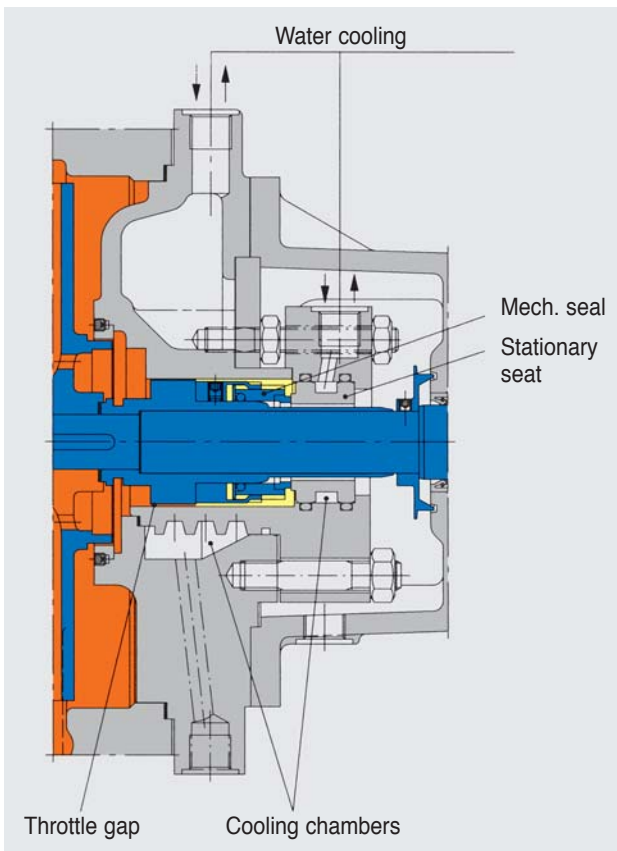

Mechanical seal "Re" with water cooled stationary seat and cooling jacket - NHL

The "Re" design requires cooling water for the stationary seat and the cooling chamber.

There is no circulation available (dead end). A throttle separates the hot pumped liquid from the cooled liquid in the seal chamber.

Cooling water consumption 300-700 l/h.

Allowable operating temperature :

NHL s max. 205°C (401°F)

NHL huh max. 238°C (464°F)

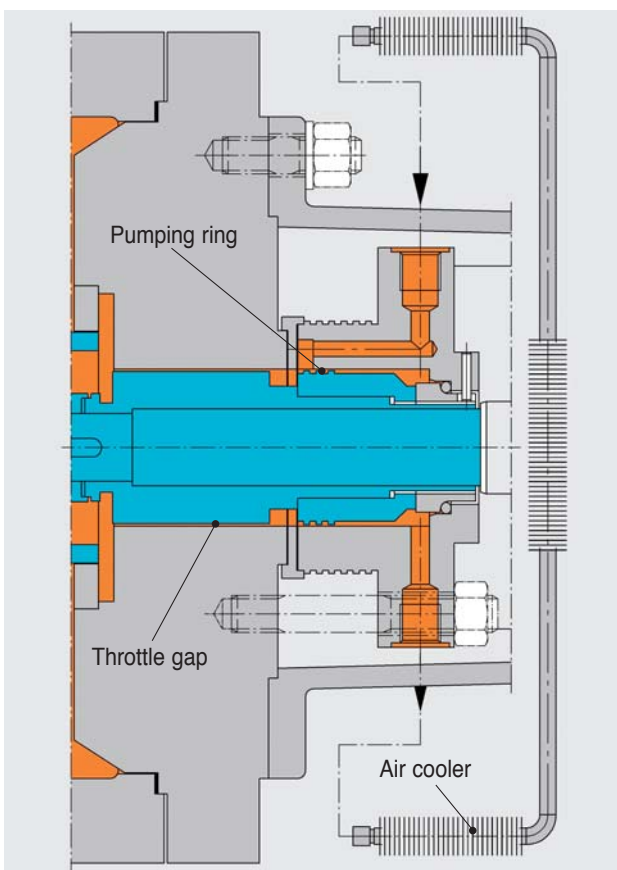

Mechanical seal "Gef" with air cooled cooling loop - NHL

A balanced single mechanical seal is provided with a pumping ring. Circulation is from the pumping ring at the seal through an external air cooler and back to the seal chamber. A pump with this cooler is also shown on the cover page.

A throttle between impeller and seal chamber separates the pumped hot water from the cooled fluid in the seal chamber. This circulation minimizes heat load on the cooling loop by cooling only the small amount of liquid that is recirculated. The arrangement is self-venting.

Allowable operating temperature :

NHL s max. 205°C (401°F)

NHL huh max. 210°C (410°F)

Mechanical seal “Ref” with circulation through water cooled heat exchanger (API-plan 23) – NHL / HPL

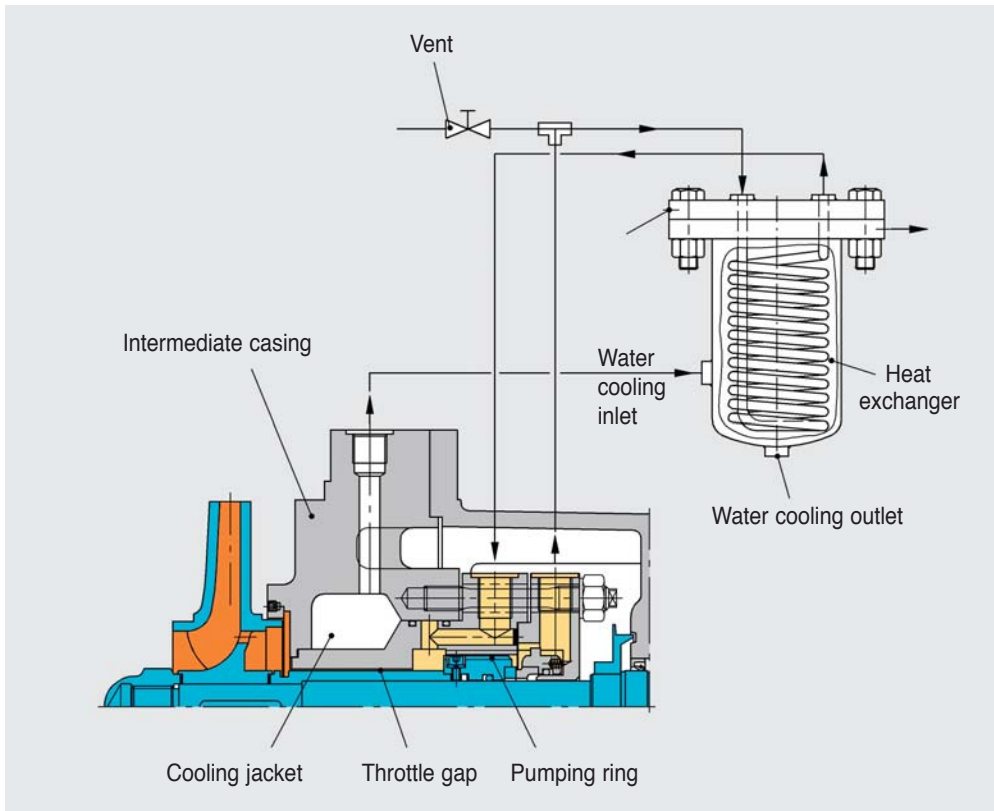

Circulation leads from a pumping ring over the seal, through a water cooled heat exchanger and back to the seal chamber. The cooling water goes through a cooling jacket in the intermediate casing and through the heat exchanger.

Cooling water consumption:
300-700 l/h.

Allowable operating temperature:

HPL / HPR	max. 280°C (536°F)
NHL huh	max. 238°C (464°F)

Pump with magnetic coupling – NHM

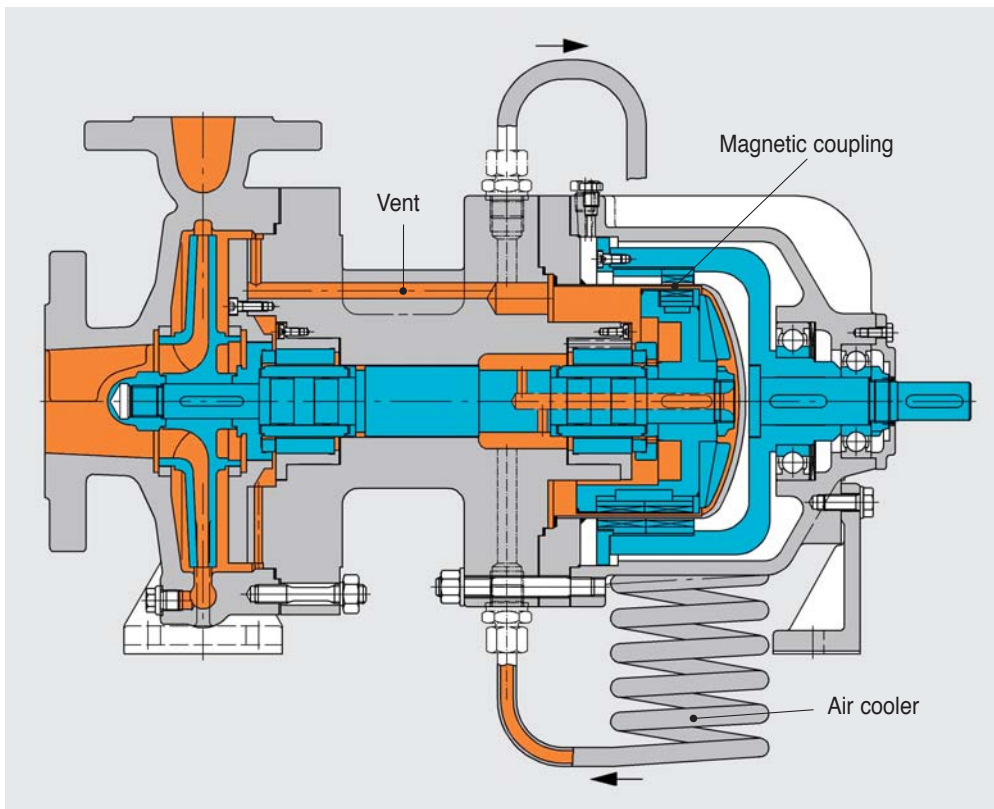

Besides common sealed pumps also sealless pumps with magnetic coupling can be used for hot water. The termination of the main wear part (the mechanical seal) lead to considerably longer “mean time between failure“ and therefore higher availability. Hot water spill through seal failure is also excluded. The pump design is self-venting and does not require water cooling.

PERFORMANCE RANGE

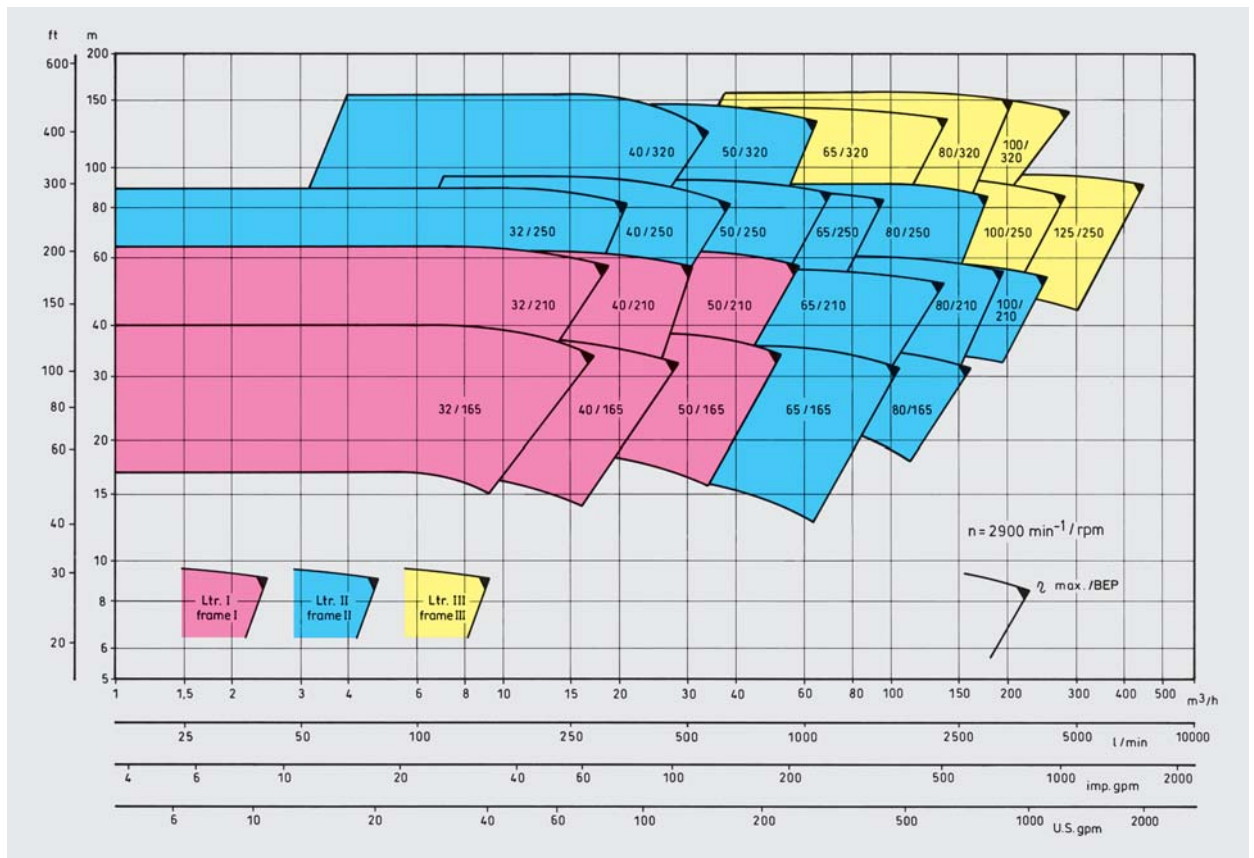
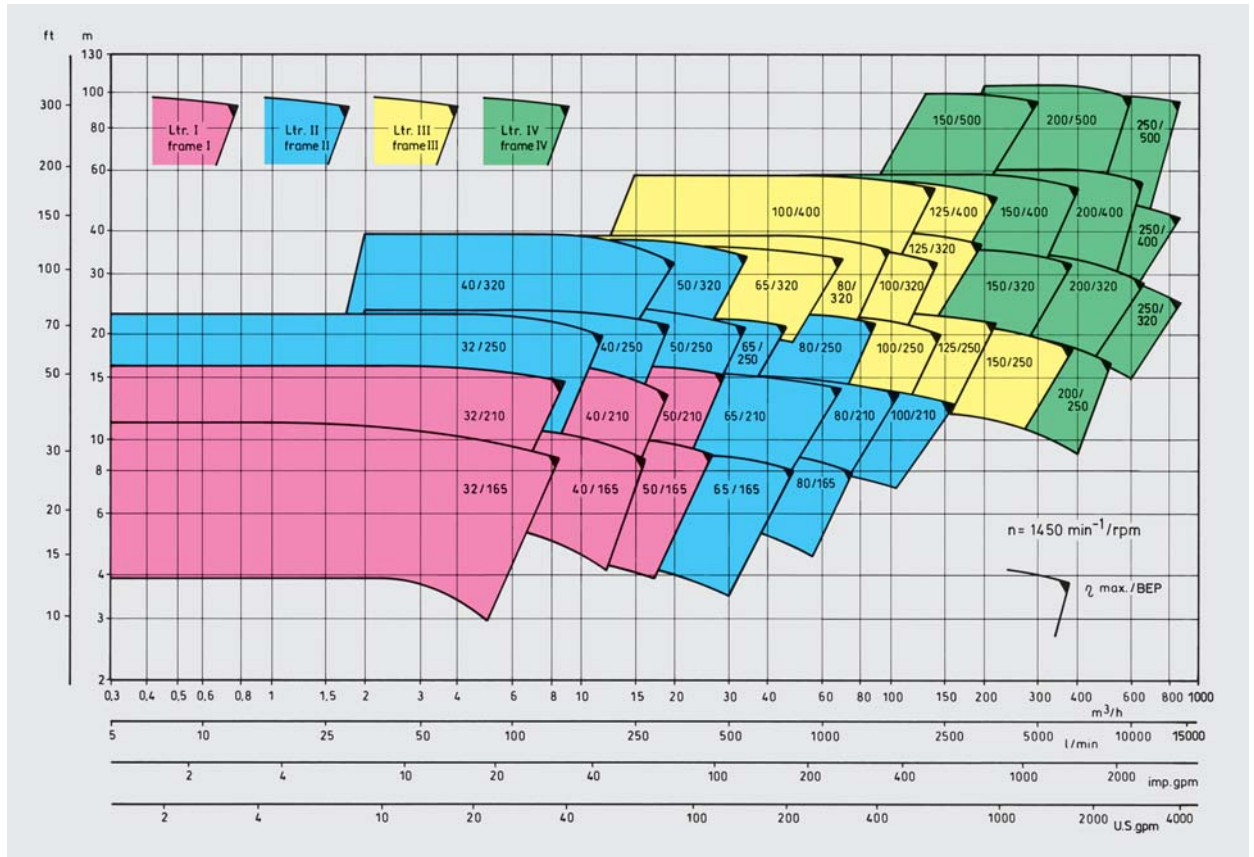

Performance curves of the individual pump sizes, also for 1750 / 3500 rpm, with NPSH-values and power consumption, are available on request.

