

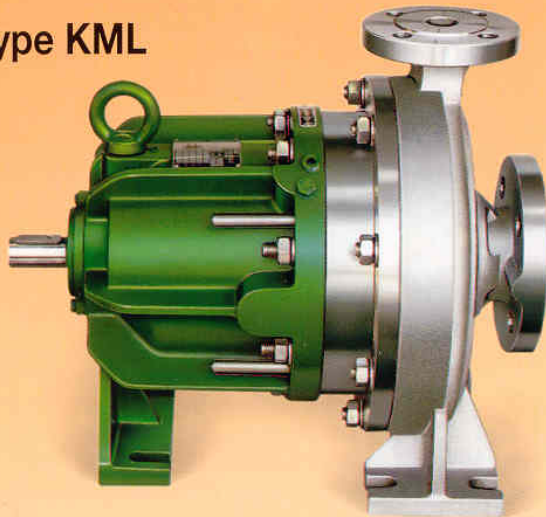

**DICKOW  
PUMPEN**



**Type KML**



**Type KMB**

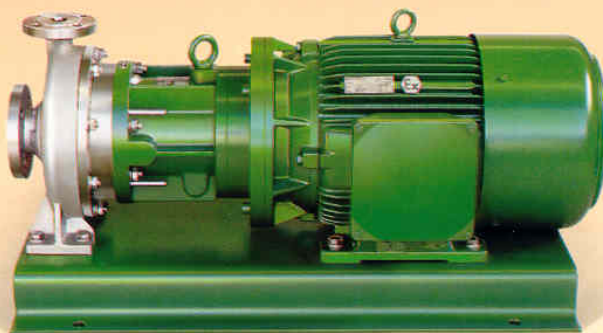

**Type KMV**

**Sealless magnetic driven  
centrifugal pumps**

ISSUE 02/00

## General

DICKOW-pumps of the series KM are sealless centrifugal pumps.

The static containment shell forms a closed system with hermetically sealed liquid end.

## Applications

Magnetic driven KM-pumps are designed to improve plant and personnel safety. Especially when handling toxic, explosive or other dangerous liquids which react on contact with the atmosphere. The KM-pumps operate maintenance-free and their containment shells replace double acting mechanical seals with external fluid reservoirs and the necessary control equipment.

Maximum capacity appr. 70 m<sup>3</sup>/h (300 US-gpm), differential head 65 mLC (213 ft). Temperature range – 30°C to 200°C (390°F), working pressure 16 bar (232 psi).

## Construction

### Horizontal design KML/KMB

The KML and KMB pumps are single stage, volute casing pumps with closed impellers, back-pull-out design, with end suction and top discharge flange. Sturdy legs are provided for foot mounting on the base plate. Capacity and casing dimensions comply with EN 22858 (ISO 2858).

For products with melting or cristallization point below ambient temperature, a design with jacketed volute casing and containment shell is available.

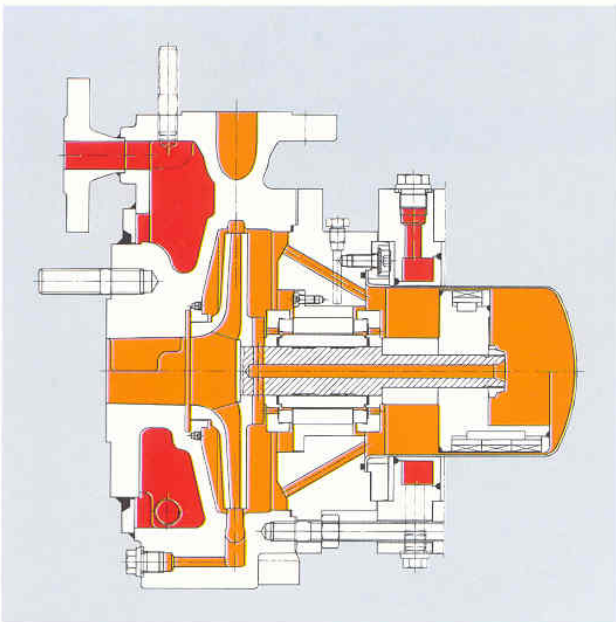

### Vertical design KMV

Type KMV is available as a space saving vertical inline-design.

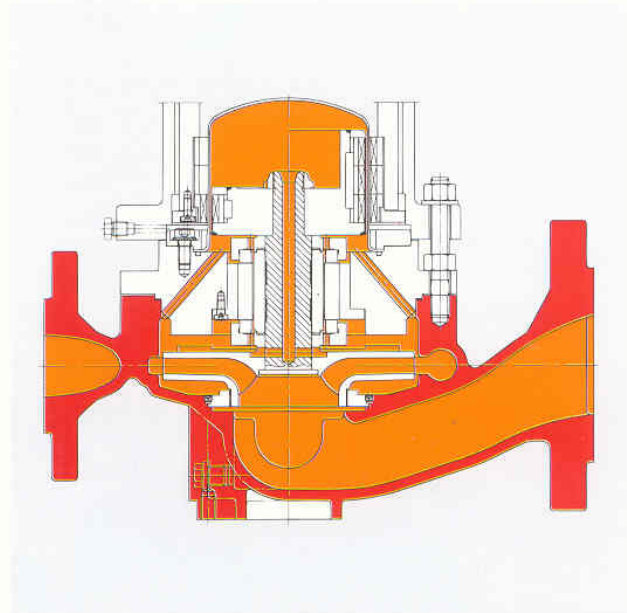

## DESIGN FEATURES

### Containment shell

The containment shell is designed as a pressurized vessel to separate the pumpage from the atmosphere. The containment shell is bolted to the bearing housing in a manner that allows removal of the bearing bracket including outer magnets and ball bearings without exposing the pumpage to the atmosphere. The shell is made of one piece and has no welds.

### Magnetic coupling

The single elements of the multipolar magnetic coupling are manufactured of a permanent magnet material "Cobalt Samarium Rare Earth".

Energy is transmitted to the hermetically sealed liquid end by a bank of external magnets passing motive force through the sealing containment shell to a bank of internal magnets. Inner and outer magnet rings are locked together by magnetic forces and work as a synchronous coupling. The inner magnet ring transmits the required torque direct to the impeller.

The rated power of the magnetic coupling is designed such that overload during normal operation is excluded, possible slipping through blocked impeller will not effect demagnetization, if temperature is monitored by sufficient devices. The magnetic drives are designed for electric motors, direct on line starting.

### Basic design KML

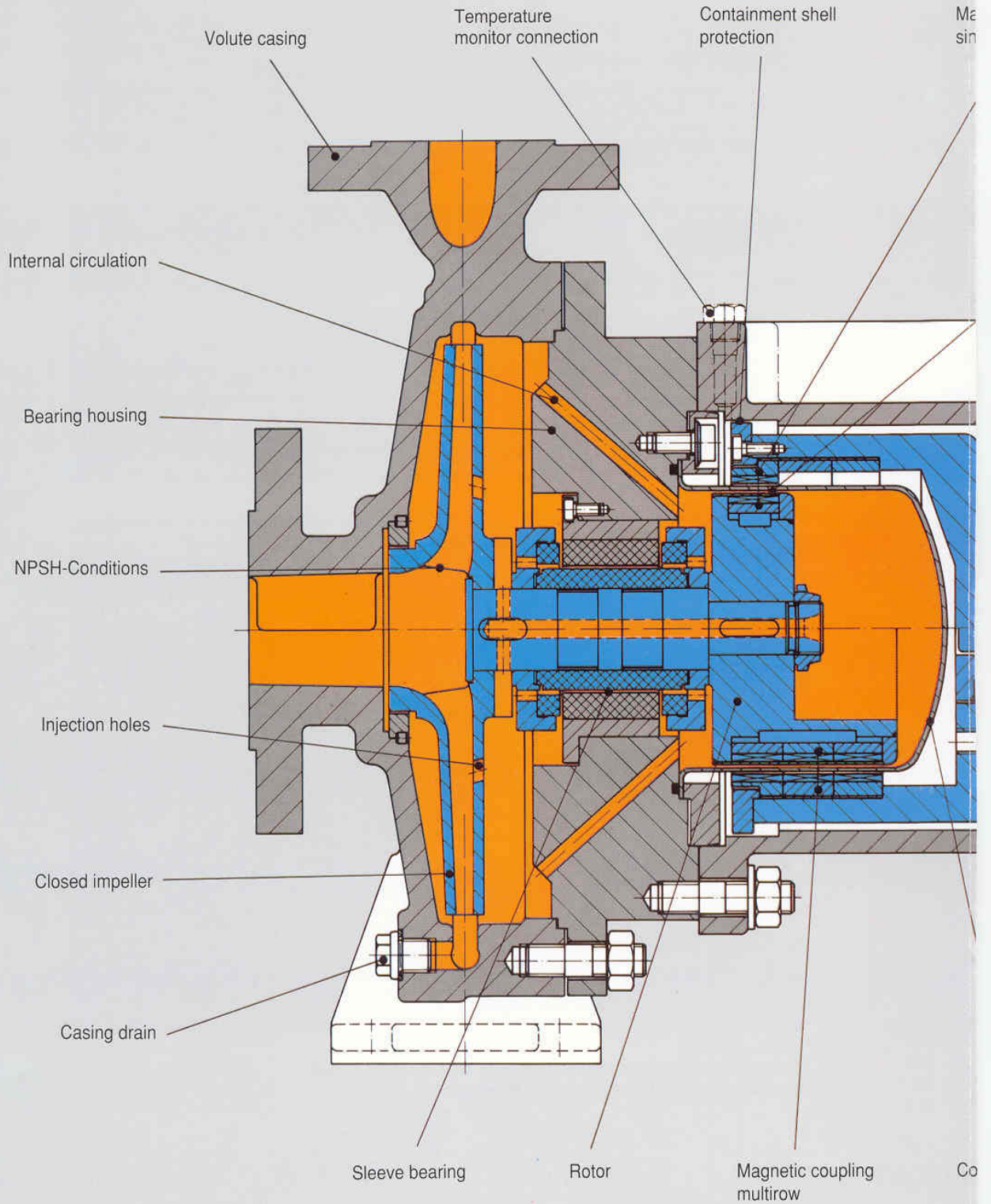

### Basic design KMB

In addition to the basic design KML, a space-saving and economical design is also available: Type KMB, direct coupled with standard motor. No additional antifriction bearings, no elastic coupling and no alignment required.

Magnetic coupling  
shell row

Internal clearances

Bearing bracket

Outer ball bearings

Containment shell

Adapter flange

Driver

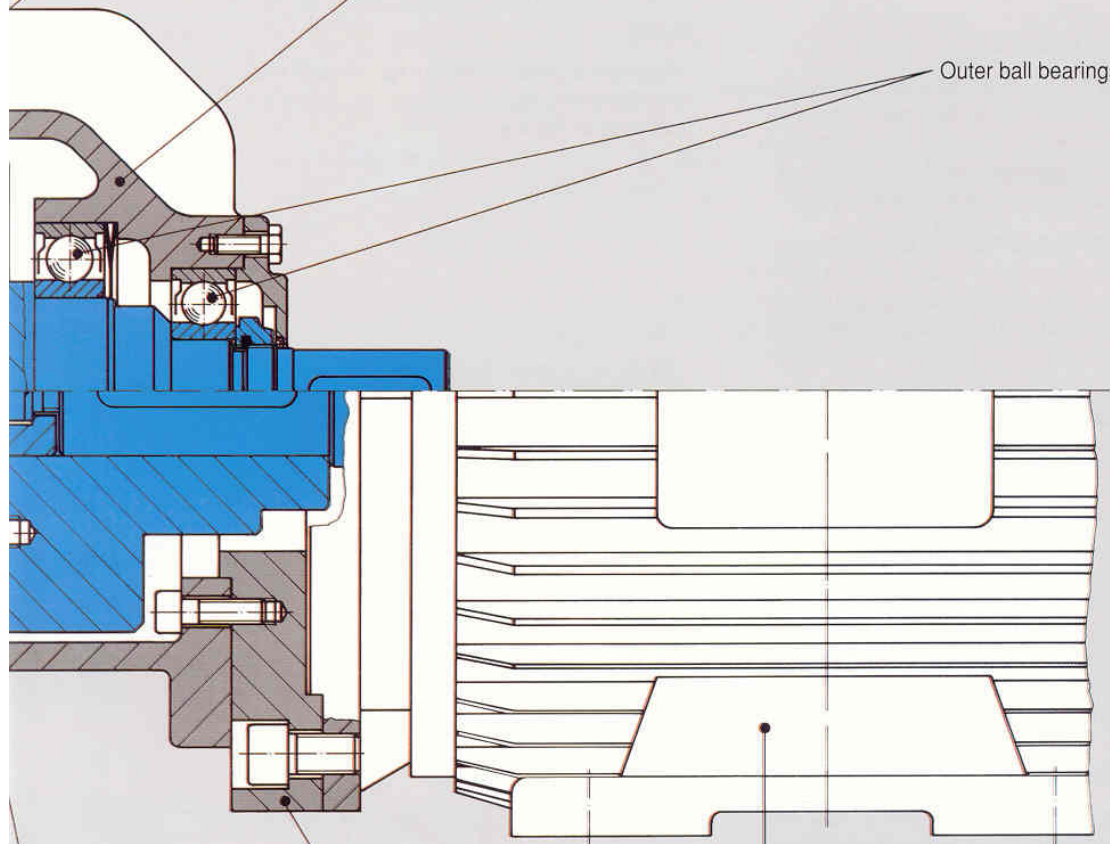

In case, a subsequent increase of motor power is required - i.e. when installing a larger impeller to meet changed process conditions - the nominal power of coupling can be increased accordingly by an additional series of magnets.

The maximum drive power is approx. 17 kW at 2900 min<sup>-1</sup> (28 HP at 3500 min<sup>-1</sup>).

### Containment shell protection

The clearances between the bearing bracket and the outer magnet coupling and between the outer magnet coupling and the containment shell are arranged to prevent the outer magnet coupling rubbing on the containment shell, even in the case of ball bearing failure.

### Outer ball bearings

The drive shaft and the drive rotor of KML-pumps are made of one piece. The drive unit is supported by generously dimensioned antifriction bearings, grease filled for life and protected against environment by a radial seal ring.

KMB/KMV-pumps have the driving magnet arranged on the motor shaft in overhung position. No additional antifriction bearings (as needed in KML-pumps) and no flexible couplings are required.

### Sleeve bearings

The pump shaft is carried in a sleeve bearing, positioned in the pumped liquid. Standard material is pure sintered Silicon Carbide with diamond layer for dry-run capability. SiC is highly resistant to corrosion and wear and applicable for all kinds of liquid. Its high hardness and wear resistance grants best possible availability. The Silicon Carbide parts are shrink fitted or elastic mounted and therefore, protected against shock and thermal stress.

### NPSH-Conditions

The fact that the internal circulation flow with elevated temperature is led back to discharge has no influence on the NPSH-value. Special impeller design achieves low NPSH-conditions.

### Balanced thrust loads

The thrust loads of the closed impellers are hydraulically balanced by impeller back vanes and injection holes. Any remaining loads are absorbed by the thrust bearings.

### Temperature control

Connection for temperature monitoring of the surface of the containment shell is available as standard. Monitoring devices for outer ball bearing are available on request.

### Casing drain

Complete drainage of casing and magnet end is possible through casing drain. No additional drain in the containment shell area is required.

### Internal circulation

Pumps in operation generate eddy currents in the metallic containment shell which heat up the product in the gap between rotor and containment shell. This heat is dissipated through an internal circulation. The internal circulation flows from discharge, directly behind the impeller, through the magnet area and is led through the pump shaft. Shaft bores create a pressure increase forcing the circulation back to the volute casing.

The effect of pressurizing the magnet end and the sleeve bearing prevents vaporization of the pumpage in this area.

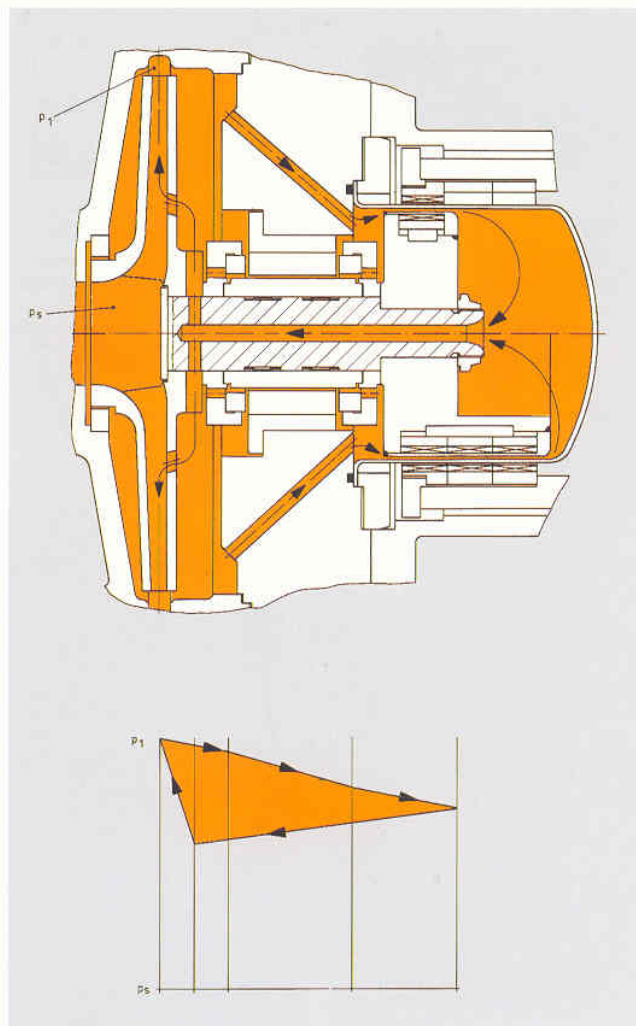

## Performance table

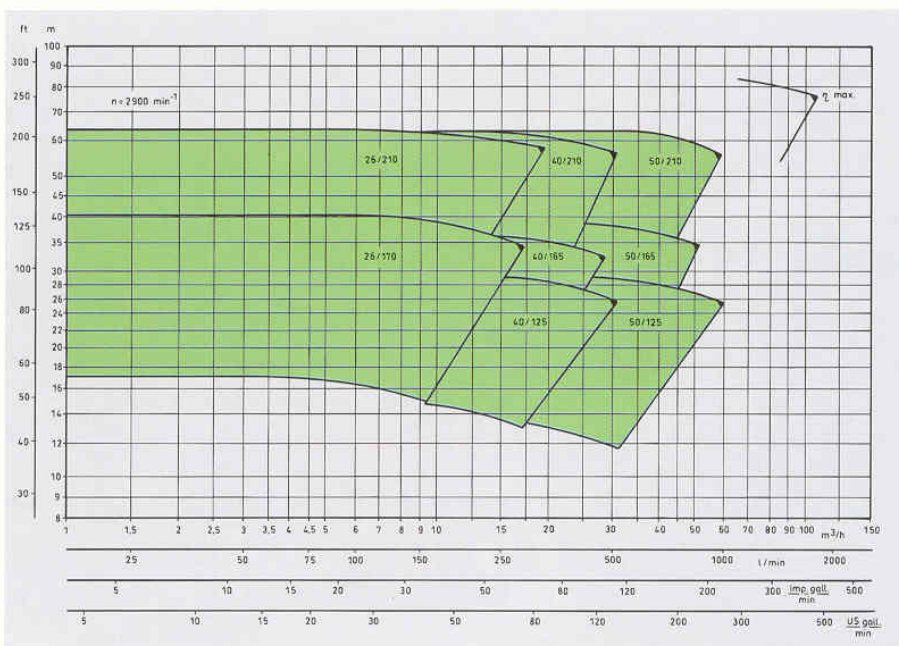
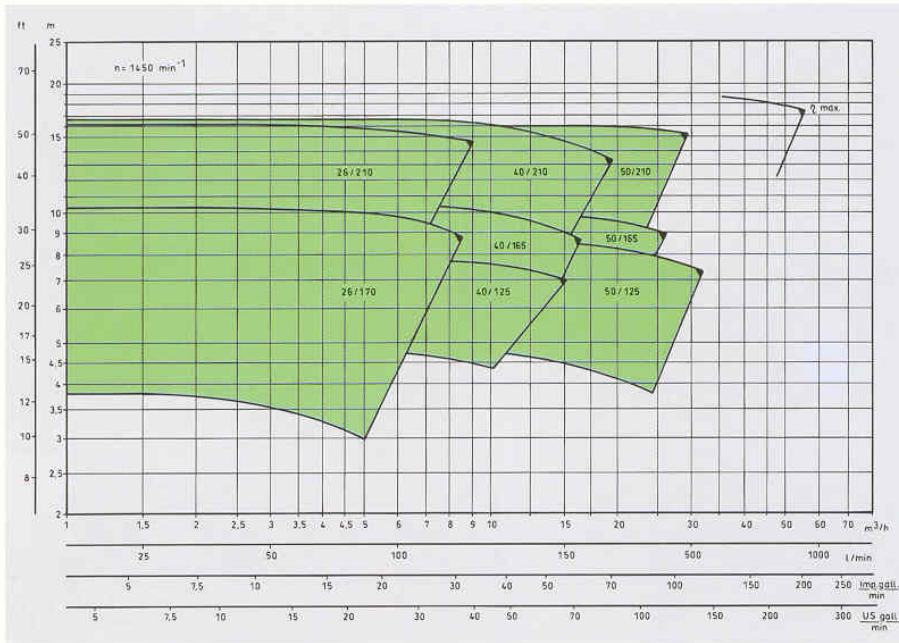

Performance curves for the different pump sizes are available on request and are supplied with our technical offers in general.

Technical changes reserved. Printed in the Federal Republic of Germany. 030-06.04 S&W



DICKOW PUMPEN KG  
P.O. BOX 1254  
D-84485 WALDKRAIBURG  
PHONE +49 (0)86 38. 602-0  
FAX +49 (0)86 38. 602-200  
e-mail: export@dickow.de

